

RT30

ROUGH TERRAIN MOBILE CRANE



360°
slew

32 ton



pick &
carry

21 ton



25 m

25 m



4x4

drive



4x4

steer

**CARRY
CRANES** 

AFFORDABLE • RELIABLE • SAFE

Specifications

Super Structure Frame

- Super Structure : All welded rigid construction.
- Counter Weight: Removable & bolted to superstructure.

Boom

- 3 Part telescopic boom fully powered & synchronized.
- Overall length Retracted -10 m; Extended- 25 m.

Boom Lifting

- Double acting single cylinder with lowering brake valve.
- Angle of elevation -1 deg. to + 83 deg.

Hoisting

Hydraulic winch with axial piston motor, grooved drum & planetary reduction gear box.

Slewing

- 360 degree rotation controlled by hydraulic motor.
- Free wheeling safety device for automatic alignment of boom over load.

Hook Block

- 32 MT swivel type hook block with 4 sheaves reeved for 8 part line with safety latch.
- Wire rope diameter of 15 / 16 mm.

Operator Cabin

Fully enclosed cabin of steel construction, sliding door & emergency exit door with large-sized safety glass windows, adjustable driver seat.

Crane Controls

- Auto reversal mechanism to ensure correct steering wheel control irrespective of the position of the superstructure in relation to the chassis.
- Operator cabin is equipped with wiper, horn, cabin fan & cab light, crane leveling gauge, free slew pedal, brake pedal, throttle pedal, dynamic brake pedal for slew, electric switch for outrigger operation, transmission gear selector, mechanical slew lock lever, air/hydraulic/pilot pressure gauge, rear steer centering indicator, hydraulic filter clogging indicator, low hydraulic oil level warning, axle lockout switch etc.
- Advanced telematics system that enables to monitor and manage crane remotely by providing information on routine maintenance & health alerts. It also provide usage data with crane movement & location.

Safety Devices

- Safety devices such as relief valves, balance valves & brake valves fitted in hydraulic system to prevent the accidents.
- Limit switch on boom head for over hoisting snatch block and on winch for over lowering with hydraulic cut off & warning.

Load Limiting Device

- Indicates boom elevation, boom length, actual load, rated load, load radius, number of falls & boom height.
- In overload condition there is audio visual warning & all such hydraulic operation that tend to increase load moment (unsafe operations) are automatically cut-off while operation like derricking in & hoisting down still being possible.

Chassis

Torsion & bending resistant with rigid steel structure box type frame made with high strength alloy steel.

Outriggers

Four nos. out and down type, hydraulically operated with fail-safe dual lock valves.

Engine

- Suitable water cooled, turbo-charged diesel engine of adequate HP.
- Fuel tank - 270 Liters.

Transmission

Power shift with build in torque converter with adequate speeds controlled from cab.

Brakes

- Service: Foot operated, hydraulically applied pneumatically assisted split circuit disc brake on all wheels.
- Parking: Hand operated lever, spring applied hydraulically released front axle mounted disc brake.

Steering

- Fully hydraulic & independent power steering operated from cab.
- Four steering modes:2-wheel (front), 2-wheel (rear), 4-wheel coordinated and crab.

Axle

- Front Axle: Drive & steer with differential & planetary reduction hubs, rigid frame mounted.
- Rear Axle: Drive & steer with differential & planetary reduction hubs, centrally pivoted, lateral oscillating with hydraulic locking device.

Drive

- 4 x 4 for off-road movement, all wheel drive
- 4 x 2 for road travel, front axle drive

Electricals

- 2 x 12 volts system
- 2 main head lamps, 2 brake and flashing trafficator lamps at rear, 2 flashing trafficator lamps at front, 1 work lamp.

Gradeability

50% (Unladen)

Hydraulic Pumps

One single pump & one double pump mounted on transmission PTO.

Hydraulic System

- Multi section 3 position proportional & flow sharing directional control valve operated by joystick for slew, telescoping, hoisting and derricking with independent or simultaneous crane operations & progressive speed control.
- Safety valves in all hydraulic cylinders for protection against pipe and hose ruptures.
- Oil cooler for cooling of hydraulic and transmission oil.

Optional Extra

- Lattice boom extension 8.5m
- Spare wheel & tyre
- Emergency wind off system
- Air conditioner
- Fire detection and suppression system
- High tension warning device
- 6 ton Hook block
- Towing hook
- Telematics System
- Centralize lubrication system
- Fog light

LIFTING CAPACITIES (IN METRIC TONNES) ON OUTHIGGERS FULLY EXTENDED AND SET SLEWING RANGE 360°

Working Radius (m)	BOOM LENGTH (m)					
	10.00	13.75	17.50	21.25	25.00	33.50
3.0	32.00					
3.5	26.70					
4.0	23.30	18.20				
4.5	20.60	18.20				
5.0	8.45	15.05	14.00			
6.0	15.15	12.60	14.00	10.20		
7.0	2.75	10.80	12.40	10.20	8.10	
8.0	10.95	9.35	10.70	9.80	8.00	4.50
9.0		7.90	9.20	8.85	7.15	4.30
10		7.00	7.80	7.90	6.60	4.09
11		6.20	6.80	6.85	6.00	3.90
12			6.10	6.25	5.55	3.69
13			5.45	5.60	5.15	3.52
14			4.90	5.05	4.65	3.34
15			4.45	4.55	4.20	3.22
16			3.95	4.15	3.85	3.08
17				3.80	3.55	2.95
18				3.50	3.30	2.83
19				3.20	3.00	2.73
20				2.90	2.75	2.61
21					2.55	2.53
22						2.44
23						2.37
24						2.28
25						2.20
26						2.07
27						1.91
28						1.77
29						1.64
30						1.48
31						1.38

LIFTING CAPACITIES (IN METRIC TONNES) MOBILE UPTO 4 KMPH SPEED OVERFRONT

Working Radius (m)	BOOM LENGTH (m)					
	10.00	13.75	17.50	21.25	25.00	
3.0	20.90					
3.5	18.80					
4.0	17.05	17.00				
4.5	15.55	15.50				
5.0	14.55	14.25	14.15			
6.0	12.30	12.25	12.15	12.10		
7.0	9.85	9.75	9.65	9.95	10.10	
8.0	7.90	7.80	7.70	8.05	8.10	
9.0		6.45	6.35	6.60	6.75	
10		5.40	5.30	5.60	5.70	
11		4.60	4.55	4.75	4.95	
12		3.90	3.85	4.10	4.25	
13			3.30	3.55	3.65	
14			2.85	3.10	3.25	
15			2.50	2.70	2.85	
16			2.20	2.40	2.55	
17				2.10	2.30	
18				1.85	2.00	
19				1.65	1.75	
20				1.45	1.60	
21					1.45	
22					1.30	
23					1.15	

LIFTING CAPACITIES (IN METRIC TONNES) FREE ON WHEELS SLEWING RANGE 360°

Working Radius (m)	BOOM LENGTH (m)			
	10.00	13.75	17.50	21.25
3.0	14.8			
3.5	13.0			
4.0	11.5	11.4		
4.5	10.3	10.2		
5.0	9.30	9.25	9.15	
6.0	7.30	7.20	7.10	7.3
7.0	5.70	5.60	5.50	5.70
8.0	4.60	4.40	4.30	4.65
9.0		3.65	3.60	3.80
10		3.00	2.95	3.15
11		2.50	2.40	2.60
12		2.10	2.00	2.20
13			1.70	1.85
14			1.35	1.55
15			1.15	1.35
16			0.95	1.15
17				0.9
18				0.75
19				0.6
20				0.5

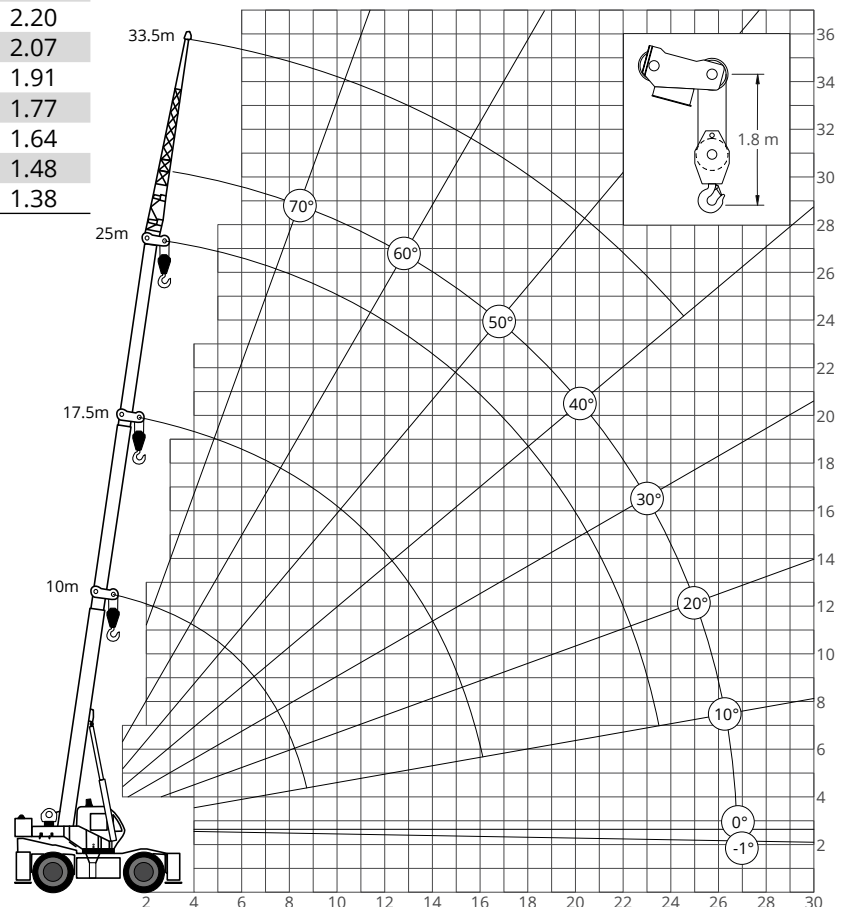

NOTES TO LOAD CHARTS

- Lifting capacities for supported operation only on firm level ground weight of 32T hook block= 350 kgs.
- Lifting capacity = Actual load + hook block + chain/slings.
- These lifting capacities should not exceed 85% of tipping load.

Permissible Hoist Line Load in kg

No. Of part line	1	2	3	4	5	6	7	8
Main winch Hook Load	4000	8000	12000	16000	20000	24000	28000	32000

Weight reduction for Load Handling Devices

8.5m Boom Lattice	
Stowed (kg)	450
Erected (kg)	1800

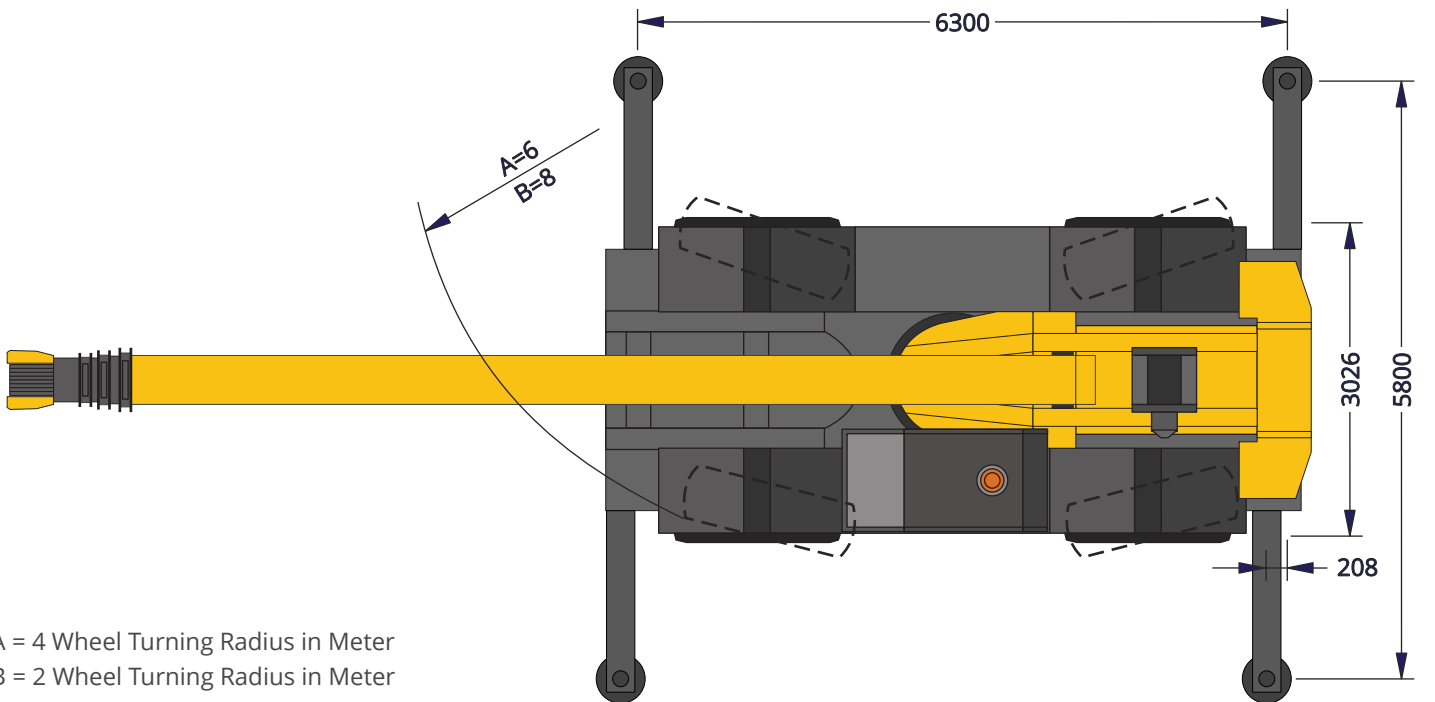
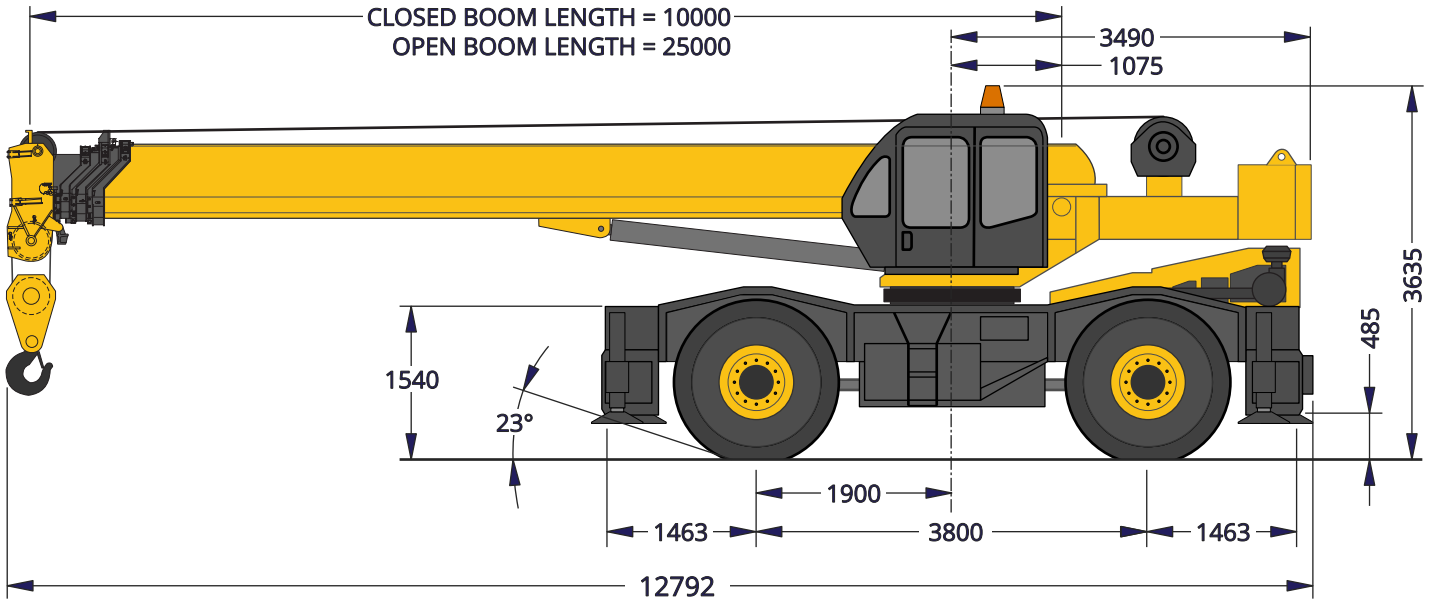

A = 4 Wheel Turning Radius in Meter
 B = 2 Wheel Turning Radius in Meter

